

IL BERSAGLIO

1 RITAGLIA IL BERSAGLIO E SCRIVI DENTRO OGNI CERCHIO I NUMERI CHE TI DICE L'INSEGNANTE.

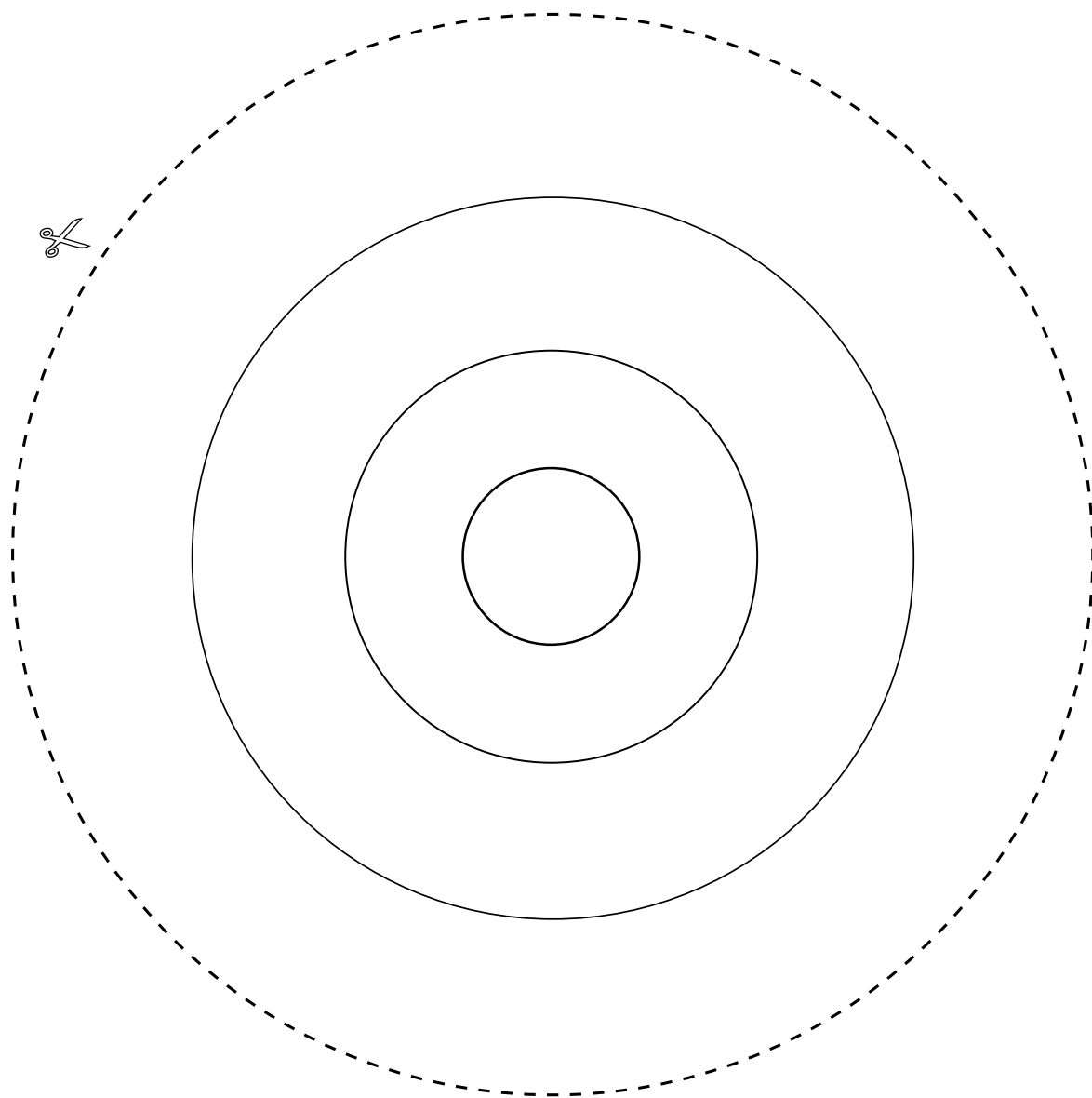

2 GIOCA E SCRIVI NELLA TABELLA I PUNTEGGI DELLA TUA SQUADRA.

NOMI	LANCIO 1	LANCIO 2	LANCIO 3	PUNTEGGIO TOTALE
.....				
.....				
.....				
.....				



CHI HA VINTO? ■ 1

1 I BAMBINI GIOCANO AL TIRO AL BERSAGLIO. GUARDA I LORO BERSAGLI E COMPLETA LA TABELLA DEI PUNTEGGI.

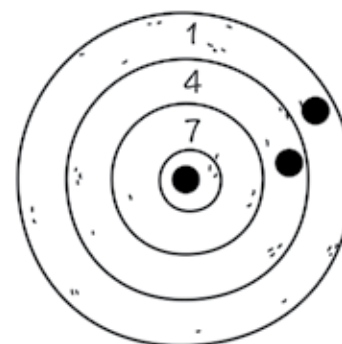
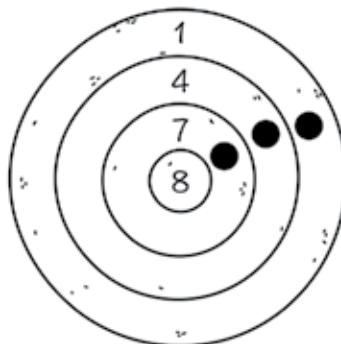
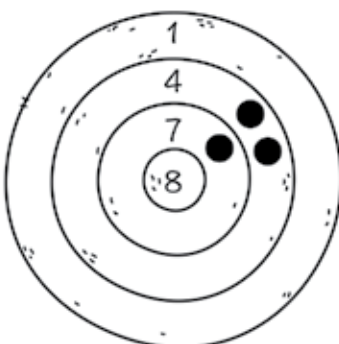
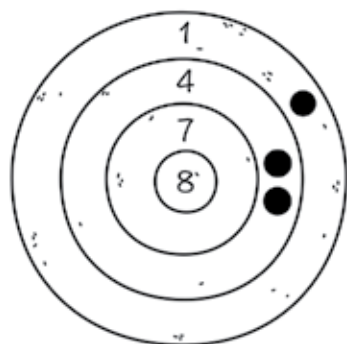

NOMI	LANCIO 1	LANCIO 2	LANCIO 3	PUNTEGGIO TOTALE
LUCA
PAOLA
GIULIA
MARCO

2 CHI HA VINTO? E CHI È ARRIVATO ULTIMO? COMPLETA LA TABELLA.

POSIZIONE	BAMBINO
PRIMO
SECONDO
TERZO
QUARTO



CHI HA VINTO? ■ 2

1 I BAMBINI GIOCANO ANCORA, MA QUESTA VOLTA A OGNI LANCIO TOLGONO DEI PUNTI. GUARDA I BERSAGLI E COMPLETA LA TABELLA.

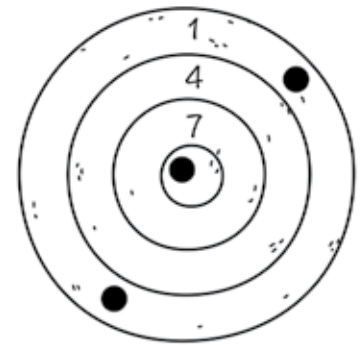
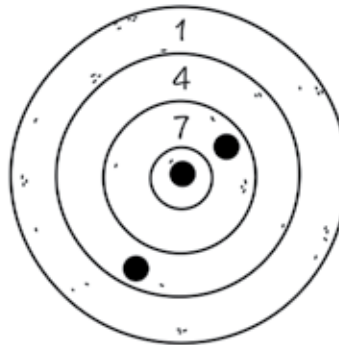
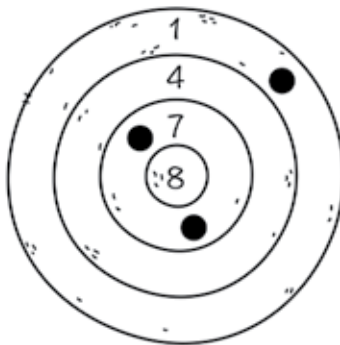
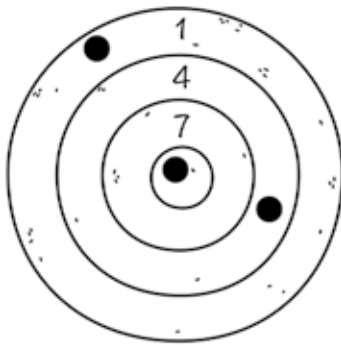

NOMI	PUNTEGGIO BASE	LANCIO 1	LANCIO 2	LANCIO 3	PUNTEGGIO TOTALE
LUCA	20	-	-	-	-
PAOLA	20	-	-	-	-
GIULIA	20	-	-	-	-
MARCO	20	-	-	-	-

2 VINCE CHI HA IL PUNTEGGIO FINALE PIÙ BASSO. COMPLETA LA TABELLA.

POSIZIONE	BAMBINO
PRIMO
SECONDO
TERZO
QUARTO

CHE COSA È ACCADUTO?

1 OSSERVA I DISEGNI E COLORA L'OPERAZIONE CHE SERVE PER RISOLVERE IL PROBLEMA.

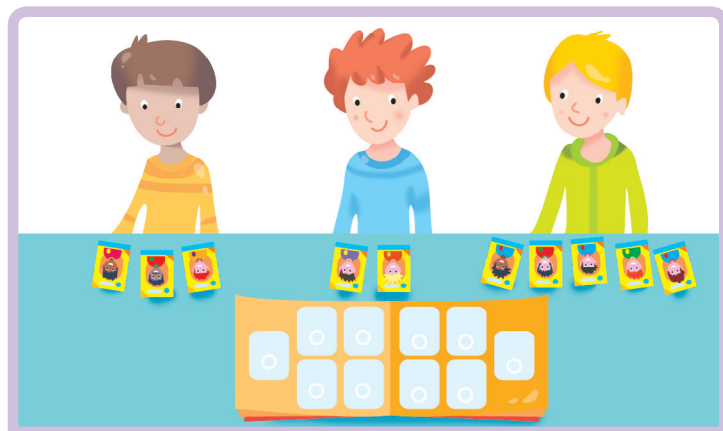

AGGIUNGERE +

TOGLIERE -



AGGIUNGERE +

TOGLIERE -

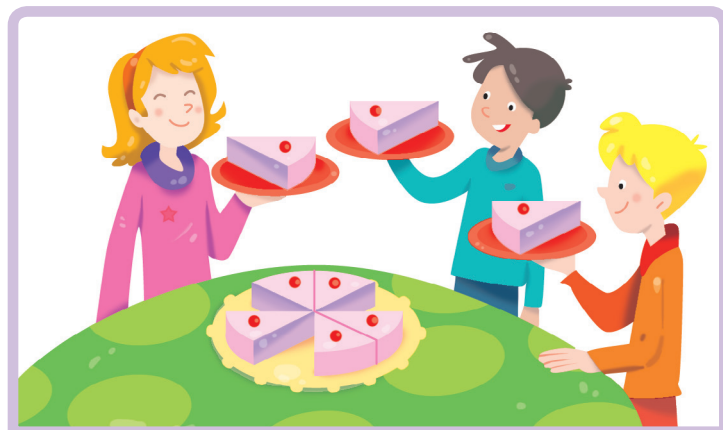

AGGIUNGERE +

TOGLIERE -

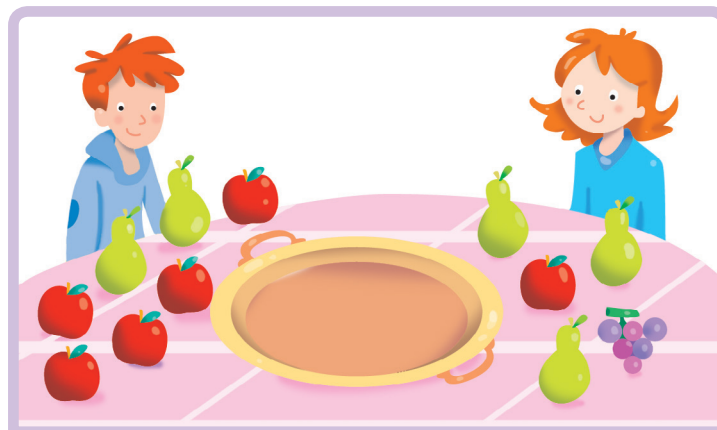

AGGIUNGERE +

TOGLIERE -



2 SPIEGA A UN TUO COMPAGNO PERCHÉ HAI SCELTO QUESTE OPERAZIONI. POI CONFRONTATEVI: AVETE SCELTO LE STESSE OPERAZIONI? DISCUTETE INSIEME.